

Sliding Gate Operator User's Manual

Model: L110C

LockMaster[®]

WholesaleGateOpener.com

OUTLINE

1. Important safety information	3
2. Main features	3
3. Technical parameters	4
4. Packing list	4
5. Installation	5
6. Electrical	8
7. Tuning and operation	11
8. Check	15
9. Maintenance	15
10. Trouble Shooting	16

1. Important safety information

Carefully read and follow all safety precaution and warnings before attempting to install and use this operator, incorrect installation can lead to severe injury.

- Installing the L110C gate operator requires installation of standard 110V electrical wiring. This work should only be performed by a trained technician. Miswiring could cause personal injury or DEATH.
- To prevent the risk of electrocution, be sure to turn off all power to the L110C until installation is complete.
- The gate operator should be installed by a qualified technician; otherwise, serious personal injury or property damage may occur.
- Before installation, the clutch should be unlocked.
- The auto-reverse function must be checked during installation to ensure that the gate can auto-reverse in the event of obstruction.
- This auto-reverse function should be regularly inspected and adjusted, if necessary.
- When opening or closing the gate, do not attempt to walk or drive through the gate.
- Do not touch the gate while it is in operation.
- Children should not be allowed to play near or operate automatic gate.
- The automatic gate operator must be grounded.
- Install the gate operator on the inside of the property, DO NOT install it on the outside of the property where the public has access to it.
- Be careful when in close proximity to moving parts where hands or fingers could be pinched.
- Additional safety equipment such as photoelectric sensors, safety edges, roller guards and warning signs must be installed to prevent injury.
- Do not allow control devices to be placed so that a person can access them by reaching through the gate.
- In the event of power failure, an emergency release key allows you to operate the gate manually.
- The operator should be switched off before repairing it or opening its cover.
- Please erase and reprogram the code after installing the operator.

2. Main features

- Infrared safety beam interface.
- User programmable and user erasable remote codes.
- RF hopping code technology prevents your remote code being accessible to others.
- Supports up to 100 remote controls.
- For your safety, the L110C will stop and reverse if it encounters an obstruction on closing and stop when it encounters an obstruction on opening.
- Manual key release design for emergency purposes.
- Auto-close feature is available for this operator.
- Pedestrian mode.
- Tighten (or release) the force adjust bolt on top of the motor to increase (or decrease) the output torque (i.e. output force of the operator), and ensure the gate safely. Adjust the output torque in the safety range before using the operator.

3. Technical parameters

Table 1

Power supply	AC110, 60Hz
Output torque (Max.)	15N • m
Motor speed	1650rpm
Reduction ratio	1:30
Limit switch	Magnetic limit switch
Auto close time	0~44 sec.
Remote control mode	Single Button
Environmental temperature	-10°C to +55°C
Emergency release key in case of power failure	

4. Packing list

After receiving the product, you should make an unpack-inspection, in which you should check whether the product was damaged. If you have any problem please contact dealer.

Table 2 Parts List

Item	Quantity
Sliding gate operator	1
Operator Bracket	1
Remote control	2
Master Links	2
Chain	1
Chain Bolts	2
Chain Brackets	2
“U” Bolts for square & round gate frame	4
2 ¾_ (M8x 70mm) Bolts for mounting operator to the bracket and washers	4
2 ½_ (M8x65mm) Bolts for mounting Magnet brackets and washers	4
3 ¾_ Anchor bolts, Anchors, Washers and Nuts	4
5/8_ (M8x15mm) Socket Head Cap screws for mounting chain box	4
Manual release key	2
Magnet brackets	2
Magnets	2
1m BVR 0.7mm ² antenna	1
User's manual	1

5. Installation

The L110C Chain-driven Gate Operator operates by forcing a straight piece of chain. This length of chain is extended between two chain brackets located at opposite ends of the gate. The entire configuration is shown in the diagram below.

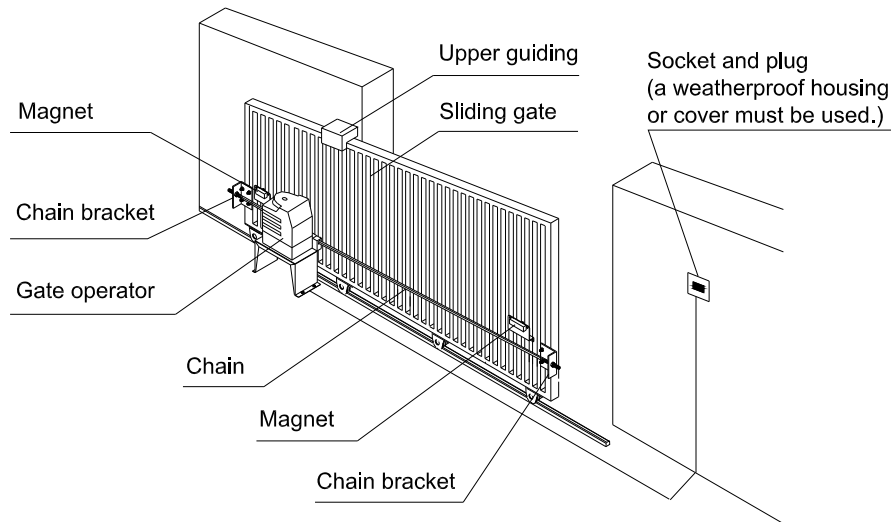

Fig.1

Conduit

In order to protect the wires, conduit must be preset into the concrete when it is poured. Wires within the conduit shall be located or protected so that no damage can result from contact with any rough or sharp part.

Concrete Pad

The base unit of the gate operator requires a concrete pad in order to maintain proper stability. The concrete pad should be approximately 300mm x 260mm x 120mm deep in order to provide for adequate operation.

Once the gate is mounted adequately, electrical power is available, and the concrete pad is poured, you are ready to proceed.

Anchors

You can use the anchor bolts, anchors, washers, and nuts see Fig.2. These anchors must be set into the concrete when it is poured, or you can use wedge anchors.

Operator Bracket

Mount the gate operator bracket to the concrete pad. The distance between the gate and the bracket should be no more than 64mm. Verify that the operator is leveled properly.

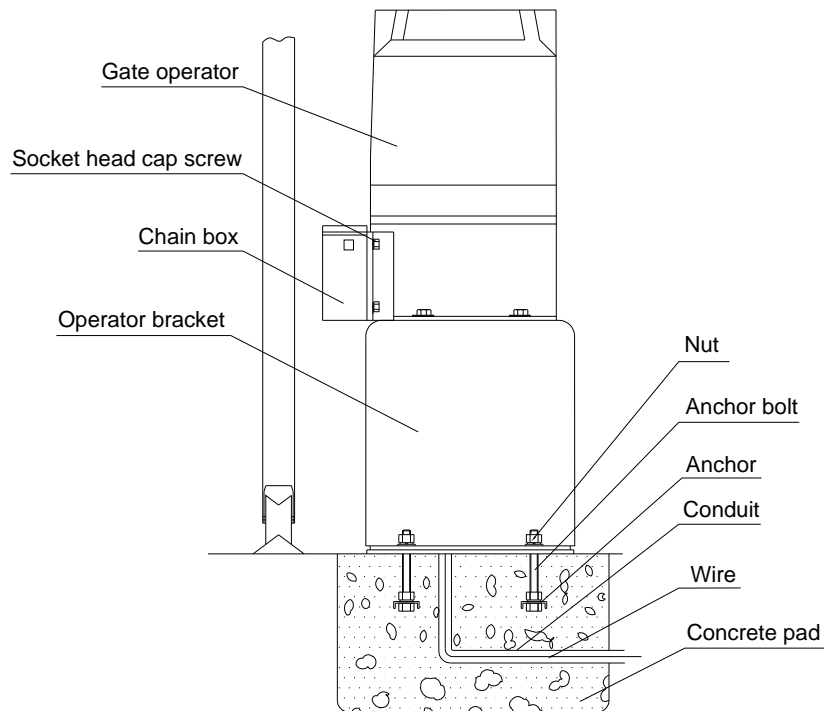

Fig.2

Chain Box

Make sure the ends of the guide chain are out of the chain holes on both sides of the chain box. Remove the cover and insert the manual release key and turn counter-clockwise to disengage the clutch. Remove the elastic band from the shaft and line up the key on the shaft with the sprocket at the chain box. Insert the sprocket from the chain box into the operator shaft. Place the operator on top of the bracket and use (4) 5/8 " (M8x15mm) socket head cap screws to mount the chain box in to the bracket. See Fig.3

Operator

Mount the gate operator to the bracket using (4) 2 3/4 " (M8x70mm) #48 bolts and washers. Check the operator and make sure it is lined up with the gate.

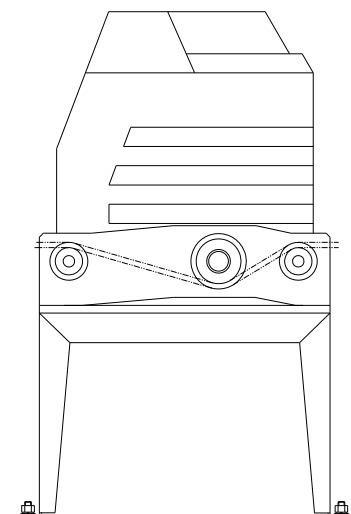

Fig.3

Chain Brackets

Use the appropriate bolts to attach the chain bracket to the frame of the gate. If the gate is of square frame style, use the square bolts shown.

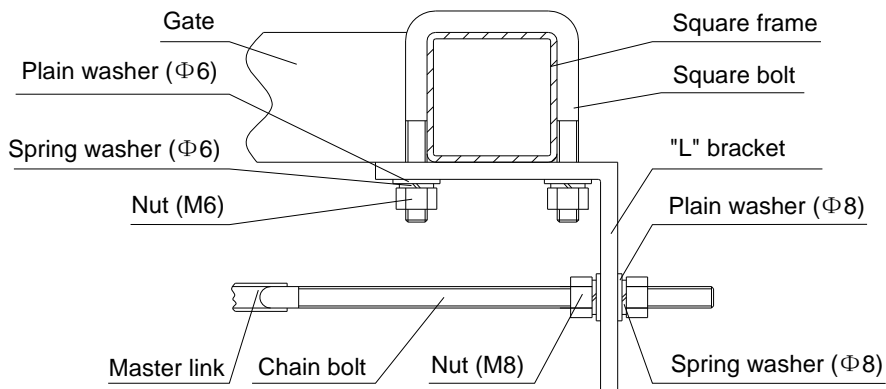

Fig.4 Top view

If the gate is of round frame style, use the round bolts shown.

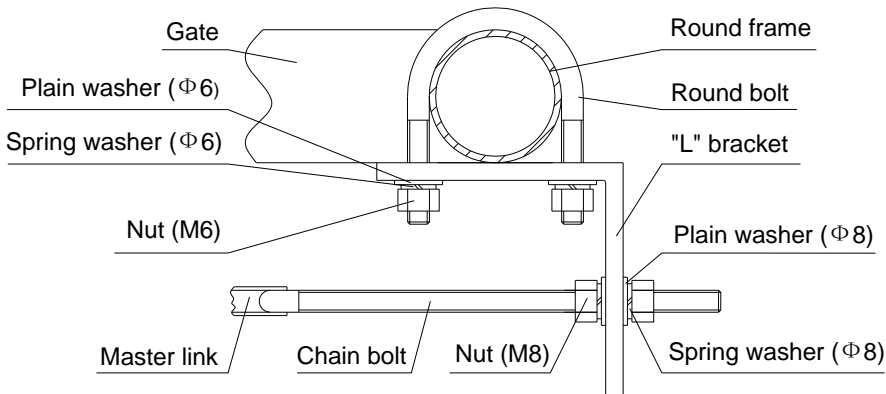

Fig.5 Top view

Chain

Close the gate and attach a chain bolt to the chain using enclosure master links. Tighten the chain bolt to the bracket with washers and nuts. Pull the chain through the sprockets to the other chain bracket at the opposite end of the gate. Connect the other end of the chain and the chain bolt, and then tighten the chain bolt to the chain bracket. Thread up the chain by adjusting the chain bolt. Cut the chain to length if necessary. Tighten the chain by tightening the chain bolts at either end. See Fig.6.

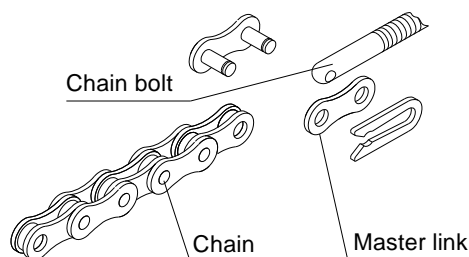

Fig.6

Magnets for limit switch (see Fig.7)

- Install the magnet as shown in Fig.7 below. The magnet and limit switch are used to control the position of the gate.
- When the magnet is installed, release the gear clutch and push the sliding gate manually to pre-determine the position. Fix the magnet bracket to the gate and then tighten the gear clutch. The lower bracket is for open position and upper bracket is for close position. Finally adjust the magnet to the proper position by moving the gate with the motor. The magnet should be 10~15mm away from the magnetic limit switch. If it is too far away, the switch will fail to work. Adjust the position of the magnet until the positions of the opening and closing meet the requirement.
- **Please note the position of two magnet brackets (fixed plate) are different: one is upper and another is lower. Verify and if necessary exchange the two brackets position. Also if necessary exchange the limit switch wires CL (close) and OP (open).**

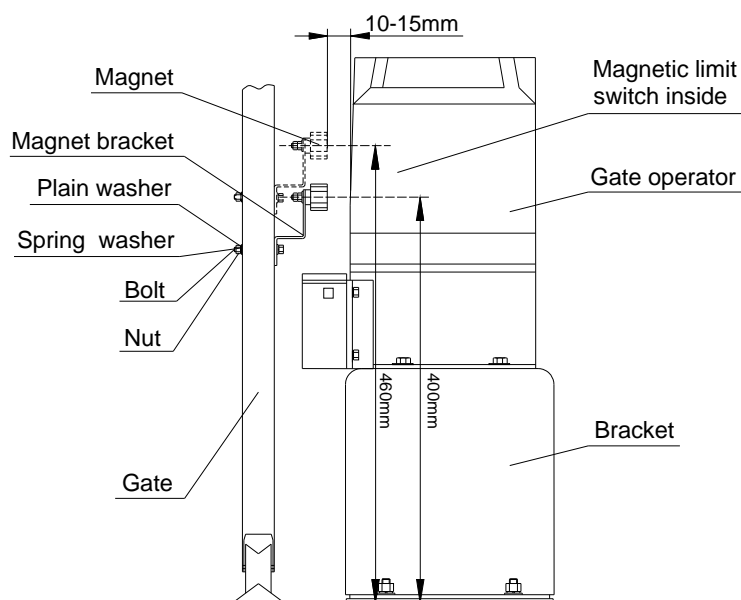

Fig.7

6. Electrical

Make sure that the power is OFF before making any electrical connections. Perform the wiring. (See control board scheme and wiring notes for control board)

Power

Using 18-3 gauge electrical wire, wire a standard grounded plug to your control board using standard electricians wiring practices. Wire the opposite end of this cable to the E, N, L contacts (block X1) of the control board. Connect L to the power line, N to the neutral line, and E to the ground line.

Control board scheme

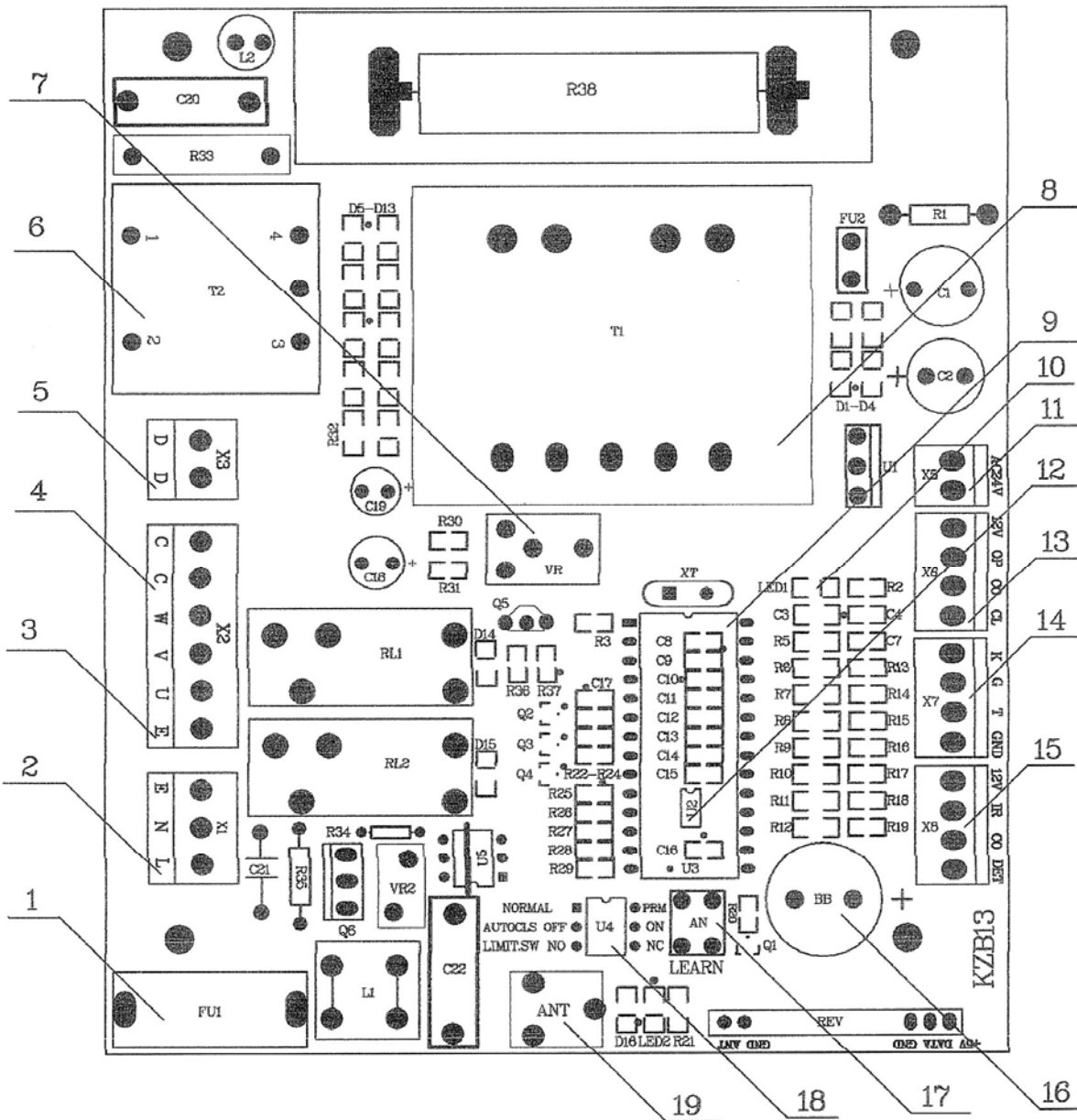
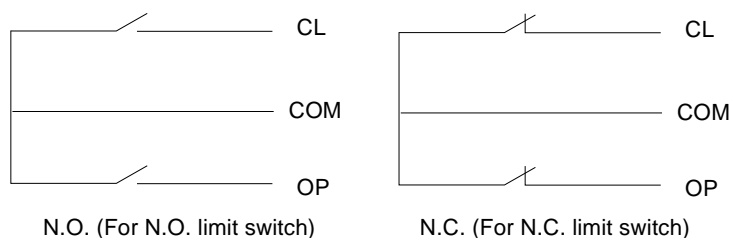

Fig.8

Wiring notes for control board

1. Fuse: 10A, Ø5x20
2. Power input: E (Earth), L (Live), N (Neutral) AC110V
3. Motor: U (com), V (Positive direction), W (Opposite direction), E (grounding)
4. Capacitor: 80uF
5. Alarm lamp: AC110V
6. Sampling transformer: 220V/12V 1W
7. Force adjustor (VR): Clockwise +, Counterclockwise –
8. Power transformer: 110V/12VX12V
9. MCU: PIC 16C57C
10. Power indicator: LED1
11. Output power supply: AC24V
12. Memory card: 93C66
13. Limit switch: CL (Close limit), CO (Com), OP (Open limit), DC12V (Output power supply)



Limit switch mode is adjustable by DIP-switch. (See table 3)

Schematic diagram

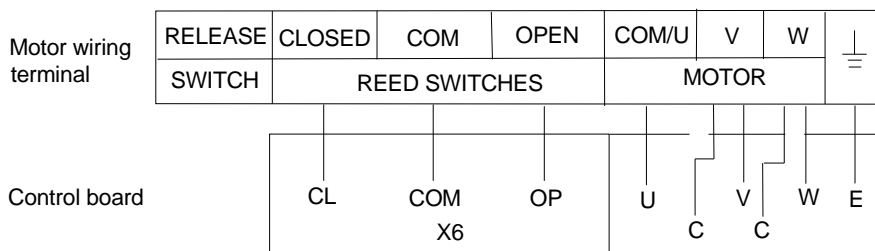

Wiring diagram

14. Single button switch / Keypad (normally open): T (Not used), G (Open priority), K (Open/stop/close), COM (Common)

To install the keypad attach one lead of your keypad to 'K' of terminal X7 and the other to the 'COM'. The keypad will function in single channel mode.

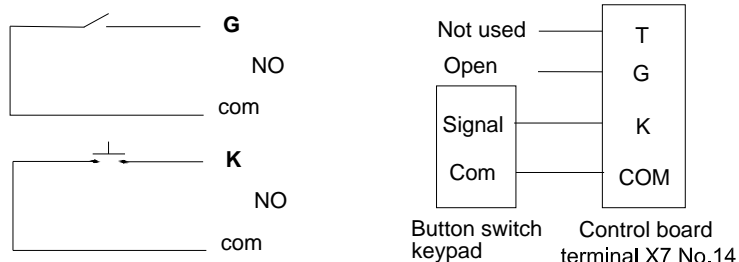

Schematic diagram

Wiring diagram

15. Output power supply: +12V (DC +12V), COM (CO), DET (Loop detector), I.R. (Infrared N.C)

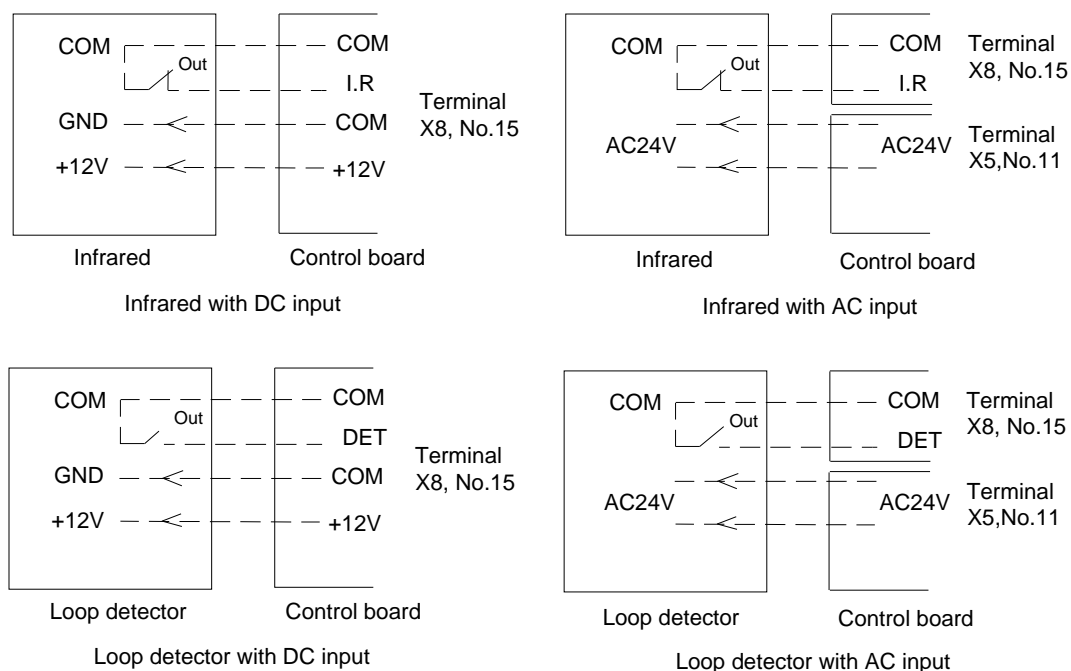

Schematic diagram

- 16. Beeper: DC12V
- 17. Learn button: AN
- 18. Dip-switch
- 19. Antenna: ANT

7. Tuning and operation

Remote control

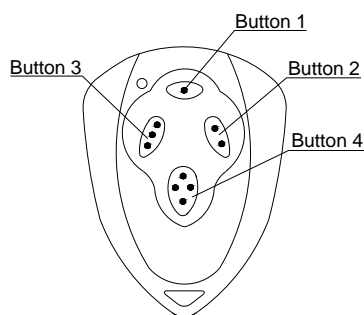

Fig.9

- **To add extra remote controls (Learning):** Press the button 'AN' (See control board scheme No.17) on the control board, then the 'LED2' will be on and turn off, the beeper will ring about 1 second, then press the remote control button which you want to use, the beeper will ring about 2 seconds and the 'LED2' will turns on about 2 seconds and then turns off. The learning process is finished. Up to 100 remote controls may be used.

- To erase all existing remote controls, press and hold 'AN' button about 14 sec until the beeper stops ringing. This indicates that all the remote controls have been erased completely.
- The remote control works in a single channel mode. It has four buttons. The function of button 1, button 2 and button 3 are the same. With each press of the remote control button which has been programmed, the gate will open, stop, close or stop cycle.
- Button 1, button 2 and button 3 are used to open or close the gate. Button 4 is available to set pedestrian mode. Note: if you canceled the pedestrian mode, the function of button 4 is same as the other three buttons.
- Warning: Notify the users that the gate is never to be operated unless it is in full view.
- Verify open direction: If the gate does not move in the desired direction, then you will need to reverse the motor operating direction. You can do this by exchanging wires 'V' and 'W', 'OP' and 'CL', then insert the wire connector terminal block.

Table 3 DIP switch
(See Fig.8 No.18)

Position	Dip Switch	Function
1	ON	Programming / In this position the control board is in programming condition, NOT USE condition.
	OFF	Normal / In this position the control board can be normally used.
2	ON	Auto-close function and auto-close function of pedestrian mode are available.
	OFF	Both Auto-close function and auto-close function of pedestrian mode are shut off.
3	ON	Limit switch mode is NC.
	OFF	Limit switch mode is NO.

- Set auto-close function (This feature can be selected to make the gate stay open for some time before it automatically closes. The auto-close time can be adjusted to between 0 and 44 seconds.): please turn on the first and the second DIP switch (See Fig.8 No.18) to ON position. Press the remote control button (button 1, button 2 or button 3) that has been programmed to open the gate (see **Verify open direction** section). Stop the gate at any position by pressing the same button, wait for some seconds according to your requirements (the range is 1~44 sec.), this period of time is regarded as 'auto-close time'. Close the gate by pressing the same button. Press the button again to stop the gate or the gate will stop automatically at its closed position if the magnetic limit switch is reached. After this setup is complete, return DIP switch 1 to OFF position immediately. Thus the auto-close function has been set.
- Cancel auto-close function: Please turn on the first and the second DIP switch (See Fig.8 No.18) to ON position. Press the remote control button (button 1, button 2 or button 3) that has been programmed to open the gate (see **Verify open direction** section). Stop the gate at any position by pressing the same button, wait until the gate close automatically (45 sec.). Press the same button to stop the gate or the gate will stop automatically at its closed position if the magnetic limit switch is reached. After this setup is complete, return DIP switch 1 to OFF position immediately. Thus the auto-close function has been

canceled.

- Pedestrian mode: Pedestrian mode can be used to open gate about 0.3~1.5 meters for people pass through.

*Set width of pedestrian mode: Please turn on the first and the second DIP switch (See Fig.8 No.18) to ON position. Press button 4 to open the gate (see **Verify open direction** section), Wait until the gate travels the distance according to your requirements (the distance range is 0.3m~1.5m or wait for 3~10 sec.), it is regarded as 'the width of pedestrian mode'. Then press the same button/button 4 to stop the gate, wait for some seconds (1~ 44 sec.). Close the gate by pressing the same button/button 4. Press the same button again to stop the gate or the gate will stop automatically at its closed position if the magnetic limit switch is reached. After this setup is complete, return DIP switch 1 to OFF position immediately. Thus the **width of pedestrian mode** has been set.

If you open the gate with button 4, the gate will stop at the expected position that you have set.

*Set auto-close function of pedestrian mode: Please turn on the first and the second DIP switch (See Fig.8 No.18) to ON position. Press button 4 to open the gate (see **Verify open direction** section), wait some seconds (3~10 sec.). Then press the same button/button 4 to stop the gate, wait some seconds according to your requirements (1~44 sec.), this period of time is regarded as 'auto-close time of pedestrian mode'. Close the gate by pressing the same button/button 4. Press the same button again to stop the gate or the gate will stop automatically at its closed position if the magnetic limit switch is reached. After this setup is complete, return DIP switch 1 to OFF position immediately. Thus the **auto-close function of pedestrian mode** has been set.

Note: the new width of pedestrian mode has been re-programmed in the device and replaced the original width you have set in **Set width of pedestrian mode** section.

If you open the gate with button 4, the gate will stop at the new expected position that you have set, after some seconds as what you have set, the gate will close automatically.

- Cancel width / auto-close function of pedestrian mode

*Cancel both width and auto-close function of pedestrian mode: Please turn on the first and the second DIP switch (See Fig.8 No.18) to ON position. Press button 4 to open the gate (see **Verify open direction** section). Wait for more than 15 sec.. Then press the same button/button 4 to stop the gate. Wait until the gate close automatically (45 sec.). Press the same button to stop the gate or the gate will stop automatically at its closed position if the magnetic limit switch is reached. After this setup is complete, return DIP switch 1 to OFF position immediately. Thus the width and auto-close function of pedestrian mode have been canceled.

*Cancel width of pedestrian mode, keep auto-close function of pedestrian mode: Please turn on the first and the second DIP switch (See Fig.8 No.18) to ON position. Press button 4 to open the gate (see **Verify open direction** section). Wait for more than 15 sec.. Then press the same button/button 4 to stop the gate. Wait some seconds according to your requirements (1~44 sec.). Then press the same button/button 4 to close the gate, press the same button again to stop the gate or the gate will stop automatically at its closed position if the magnetic limit switch is reached. After this setup is complete, return DIP switch 1 to OFF position immediately. Thus the width of pedestrian mode has been canceled, the auto-close function of pedestrian mode has been reserved.

Note: the new auto-close time of pedestrian mode has been re-programmed in the device

and replaced the original auto-close time of pedestrian mode that you have been set in **Set auto-close function of pedestrian mode** section.

*Keep width of pedestrian mode, cancel auto-close function of pedestrian mode: Please turn on the first and the second DIP switch (See Fig.8 No.18) to ON position. Press button 4 to open the gate (see **Verify open direction** section). Wait some seconds (3~10 sec.), then press the same button/button 4 to stop the gate. Wait until the gate close automatically (45 sec.). Press the same button again to stop the gate or the gate will stop automatically at its closed position if the magnetic limit switch is reached. After this setup is complete, return DIP switch 1 to OFF position immediately. Thus the width of pedestrian mode has been reserved, the auto-close function of pedestrian mode has been canceled. Note: the new width of pedestrian mode has been re-programmed in the device and replaced the original width.

If you open the gate with button 4, the gate will stop at the expected position that you have set, but the gate will not close automatically.

- Turn on the second DIP switch to OFF position (Factory preset: OFF position), both auto close function and auto-close function of pedestrian mode were shut off.
- Safe guard (Infrared device): If the infrared beam is broken during closing, the gate will reverse and open immediately.
- Tuning the auto-reverse safety function: rotate the 'Force Adj. VR' knob (See Fig.8 No.7) with a screwdriver. The opening & closing force may be increased or decreased by rotating clockwise or counterclockwise. NOTE: if the gate fails to reverse in the event of obstruction, then the opening force or closing force should be checked for conformity with requirements and adjusted accordingly. The gate will reverse if obstructed when closing, and will stop if jammed when opening.
Please exchange wires 'V' and 'W' if the auto-reverse direction is wrong. Exchange wires 'OP' and 'CL' if the limit direction is wrong.
- **WARNING:** Do not attempt to tune the gate by placing your hand, arm or other body part in the path of the gate, as serious injury could result. Damage to the gate operator motors may also occur by placing a heavy immovable object in the path during the testing phase. Instead, place a light object in the path (e.g., a chair or trash can) which can be pushed out of the way without causing damage to gate motors, if the setting is still too high. Note: This auto reverse function should be regularly inspected and adjusted if necessary. Once the tuning is complete you may replace the cover.

Activities Covered in this section

- **Remote control (Single-button mode):** With each press of the button, the gate will open, stop, close or stop cycle.
- **Single-button switch/keypad (not supply):** with each press of the button, the gate will close, stop, open or stop cycle.
- **Auto-reverse function:** After adjusting the opening force and closing force, the gate will reverse and go open if obstructed when closing, and will stop if jammed when opening.
- **Auto-close function:** This feature can be selected to make the gate stay open for several seconds before it automatically closes. The auto-close time can be adjusted to between 0 and 44 seconds.

- **Pedestrian mode:** This feature can be used to open gate about 0.3~1.5 meters for people pass through.
- **Safe guard (Infrared photocell):** If infrared beam is broken during closing, the gate will reverse and go open immediately. This feature will not function if the gate is in fully opened and closed positions or during opening.
- **Open priority:** The gate will return to open if press 'OPEN' button of external button switch during closing.
- **Loop detector:** If loop detector detects vehicles during closing, the gate will reopen immediately and stay open until the vehicles move out of the loop. After vehicles move out of the loop, the gate will continue to close.
If loop detector detects vehicles when the gate stops, the gate will remain stop until vehicles move out of the loop. After vehicles move out of the loop, the gate will close.
The gate will keep opening if loop detector detects vehicles during opening. After vehicles pass through the loop, the gate will close.

8. Check

- Check the power supply, grounding and wiring before running the device.
- Release the clutch with the release key to determine whether or not the gate can be moved manually. If everything is in good working order, tighten the clutch with the key.
- Switch the power on and run the device to ensure that the gate is sliding smoothly.
- Adjust the magnet position until the gate opened and closed properly at the limited positions.

9. Maintenance

Every six months check the following items for proper operation of the unit.

- Loosen the oil screw on the motor to avoid leakage.
- Check the chain lubricant and add 2# grease regularly.
- Lubricate shafts and sprockets.
- Keep operator clean at all times.
- Check and tighten anchors bolts.

10. Trouble Shooting

Table 4

Trouble	Possible causes	Solutions
Motor only runs in one direction.	The wire connector terminal block becomes loose.	Check wire connector terminal block.
	The limit switch wire connector terminal block becomes loose.	Check limit switch wire connector terminal block. Check the limit switch mode.
By pressing button 1(button 2 or button 3) which has been programmed to open the gate, press the same button again to stop the gate in required position, but the gate will auto-close immediately.	The auto-close time is too short.	Reset the auto-close time. See Set auto-close function section.
When you use button 4 of remote control to open the gate, gate travels too short.	The width of pedestrian mode is too narrow.	Reset the width of pedestrian mode. See Set width of pedestrian mode section.
When you use button 4 of remote control to open the gate, but the gate will auto-close immediately.	The auto-close time of pedestrian mode is too short.	Reset the auto-close time of pedestrian. See Set auto-close function of pedestrian mode section.
The gate will not open or close.	The limit switch wire connector terminal block becomes loose.	Check the limit switch mode (see table 3 DIP switch).
	Connecting wires or terminal blocks are too loose.	Check the connecting wires and terminal blocks.
	Power switch is OFF.	Make sure power switch is ON.
Remote control does not work.	The indicator light of remote control does not light.	Check the batteries on your remote control.
	Remote control is not suitable for receiver.	After making sure the codes are correct, erase remote controls and then re-program the codes in the device. See Adding extra remote controls (learning) section.
	Broken receive board.	Replace receive board.
When you open the gate by using button 1(button 2 or button 3) which has been programmed, gate will stop in mid-travel or reverse before reaching the fully limit position.	The Force Adj. (VR) is adjusted too small.	Check the Force Adj. (VR). Adjust VR to increase force.
	Gate is obstructed.	Remove the obstruction.
The remote control operating distance is too short.	Signals are shielded by the gate.	Link a new antenna (1~1.2m BVR 0.75mm ² see parts list) to the old antenna. Then fix the antenna on the wall vertically, make sure the total height from the top of antenna to the ground is approx. 1.5m.
The gate opens, but stops and will not return.	1. Please note the two magnet brackets (fixed plate) are different: one is higher and another is lower. Please try to exchange the two brackets position. 2. Please try to exchange the limit switch wires CL (close) and OP (open).	There are two reed switches inside the magnetic limit switch: one is upper and another is lower. Maybe the magnet position was installed in the middle so it inducts both reed switches. Solution: adjust the magnet upper or lower.